

Central frequency - 260.2 MHz

Passband - 3.8 MHz

Complies with Directive 2002/95/EC (RoHS)

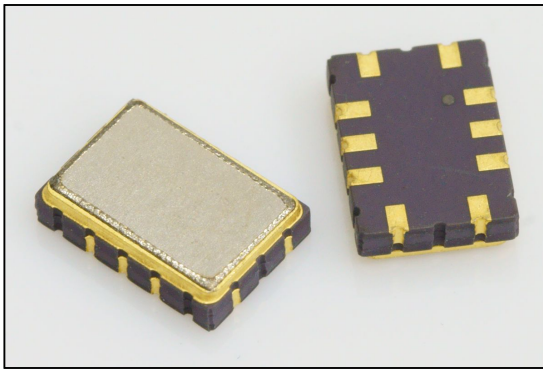

Looking for information on other SAW devices at: <http://aec-pro.com/filters.php>

Designed by: Ltd. AEC Design

Mass production: Ltd. AEC

TYPICAL PERFORMANCE

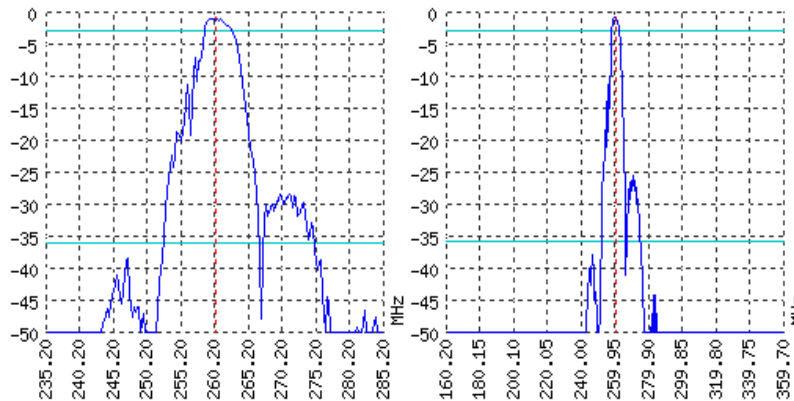

SPECIFICATIONS

Parameter	Unit	Low frequency	Typical	Upper frequency
Central frequency	MHz	-	260.2	-
Insertion loss	dB	-	Not more 1.5	-
Bandwidth edge -2dB level	MHz	Not more 258.46	-	Not less 261.94
Bandwidth edge -35dB level	MHz	Not less 251	-	Not more 275.5
Amplitude ripple	dB	-	Not more 2	-
Group Delay Ripple	ns	-	-	-
Ultimate rejection	dB	-	35	-
Operating temperature	°C	-55	22	+85
Substrate	-	-	Lithium tantalate 36	-

Notes:

- For information. Order a ЦПАР.433561.53 TY for a complete and updated data.
- Specification valid for measurements in AEC test fixture.

CASE QCC 12B

MATCHING

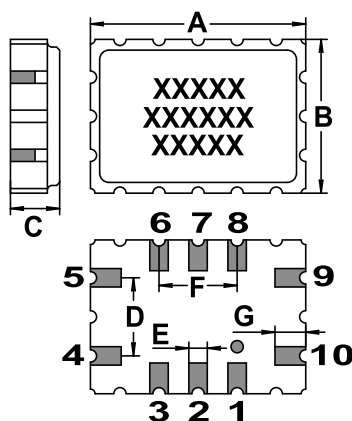

<http://aec-pro.com/cases.php>



DIMENSIONS (mm)	
A	7
B	5
C	1.6
D	2.54
E	0.6
F	2.54
G	1

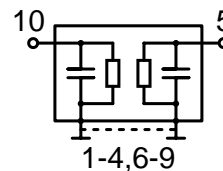

Input 50 Ohm		Output 50 Ohm	
L1, nH	-	L2, nH	-
C1, pF	-	C2, pF	-

Signal input: 10
Signal output: 5
Ground: other pin

*Matching condition depends on PCB layout.

Recommendations:

- See the relevant ЦПАР for maximum permissible input signal power in the bandwidth.
- Input signal amplitude in the stop band is limited to 5 V.
- DC voltage at the input (output) of the filter should not exceed 10 V.
- It is recommended to include the coupling capacitor between the device and the generator (load).
- SAW filters are sensitive to static electricity, therefore corresponding precautions should be taken while working with them.
- Do not expose the device to frequency vibrations more than 5 kHz. Do not use ultrasonic cleaners.

Design and production SAW filters, resonators, delay lines, sensors.

AEK Ltd. AEC Mass production. Acceptance - QCID.
aec@aec-pro.com | tel./fax (812)252-93-70

AEC Ltd. AEC Design Design and production. Military acceptance.
admin@aec-design.com | tel.(812)377-04-26 | fax.(812)364-60-69