

Central frequency - 361.4 MHz

Passband - 16 MHz

Complies with Directive 2002/95/EC (RoHS)

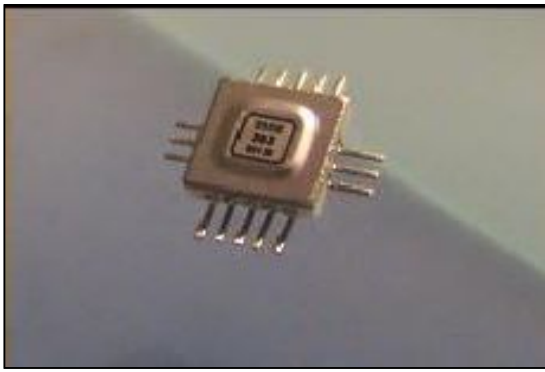

Looking for information on other SAW devices at: <http://aec-pro.com/filters.php>

Designed by: Ltd. AEC Design

Mass production: Ltd. AEC

TYPICAL PERFORMANCE

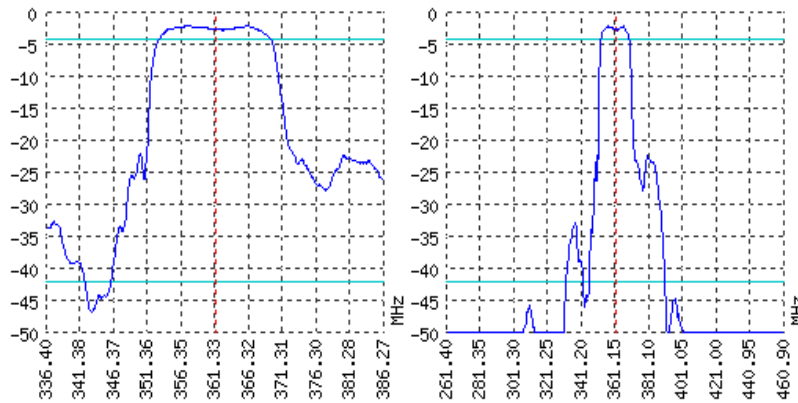

SPECIFICATIONS

Parameter	Unit	Minimum	Typical	Maximum
Central frequency	MHz	360.9	361.4	361.9
Insertion loss	dB	2	2.2	2.3
Bandwidth at -2 дБ	MHz	15.5	16	-
Bandwidth at -40 дБ	MHz	-	58.5	-
Amplitude ripple	dB	-	1.7	2
Group Delay Ripple	ns	-	-	-
Ultimate rejection	dB	-	55	-
Operating temperature	°C	-55	22	+85
Substrate	-	-	Lithium niobate 64	-

Notes:

1. The design, manufacturing process, and specifications of this filter are subject to change.
2. Specification valid for measurements in AEC test fixture.

CASE H 02.16-2BH

MATCHING

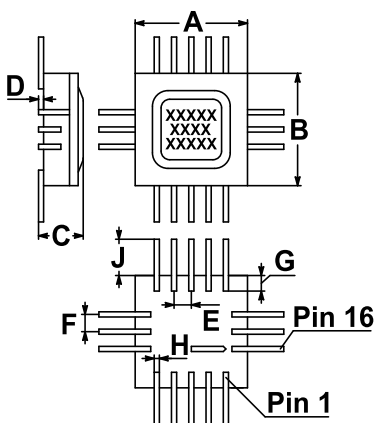

<http://aec-pro.com/cases.php>



DIMENSIONS (mm)	
A	6.5
B	6.5
C	2.9
D	0.2
E	1
F	1
G	0.9
H	0.3
J	3

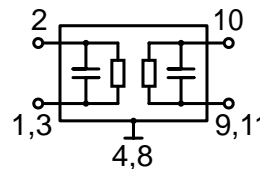

Input 50 Om		Output 50 Om	
L1, nH	-	L2, nH	-
C1, pF	-	C2, pF	-

Signal input: 2  
 Ground (input): 1,3  
 Signal output: 10  
 Ground (output): 9,11  
 Ground: other pin

\*Matching condition depends on PCB layout.

Recommendations:

1. See the relevant ЦПАП for maximum permissible input signal power in the bandwidth.
2. Input signal amplitude in the stop band is limited to 5 V.
3. DC voltage at the input (output) of the filter should not exceed 10 V.
4. It is recommended to include the coupling capacitor between the device and the generator (load).
5. SAW filters are sensitive to static electricity, therefore corresponding precautions should be taken while working with them.
6. Do not expose the device to frequency vibrations more than 5 kHz. Do not use ultrasonic cleaners.

Design and production SAW filters, resonators, delay lines, sensors.

**AEK** Ltd. AEC Mass production. Acceptance - QCID.  
[aec@aec-pro.com](mailto:aec@aec-pro.com) | tel./fax (812)252-93-70

**AEC** Ltd. AEC Design Design and production. Military acceptance.  
[admin@aec-design.com](mailto:admin@aec-design.com) | tel.(812)377-04-26 | fax.(812)364-60-69