

Central frequency - 414.5 MHz

Passband - 6.3 MHz

Complies with Directive 2002/95/EC (RoHS)

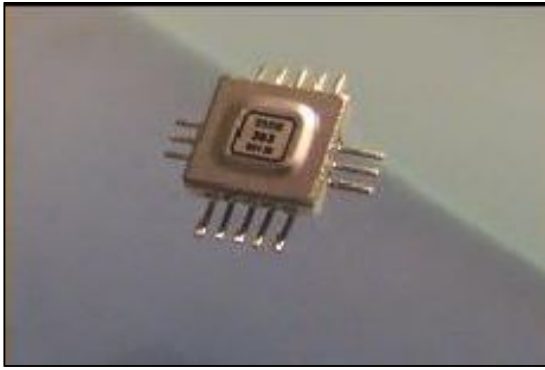

Looking for information on other SAW devices at: <http://aec-pro.com/filters.php>

Designed by: Ltd. AEC Design

Mass production: Ltd. AEC

TYPICAL PERFORMANCE

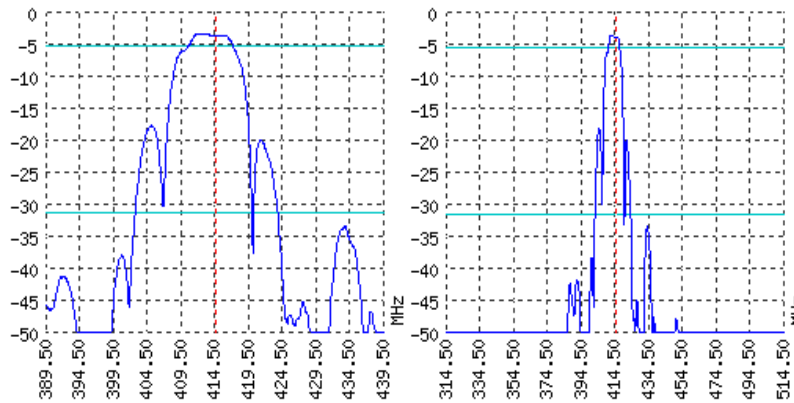

SPECIFICATIONS

Parameter	Unit	Low frequency	Typical	Upper frequency
Central frequency	MHz	-	414.5	-
Insertion loss	dB	-	Not more 3.8	-
Bandwidth edge -2dB level	MHz	Not more 411.65	-	Not less 417.35
Bandwidth edge -28dB level	MHz	Not less 401.75	-	Not more 427.25
Amplitude ripple	dB	-	Not more 2	-
Group Delay Ripple	ns	-	-	-
Ultimate rejection	dB	-	28	-
Operating temperature	°C	-55	22	+85
Substrate	-	-	Lithium niobate 128	-

Notes:

- For information. Order a ЦПАР.433561.58 TY for a complete and updated data.
- Specification valid for measurements in AEC test fixture.

CASE H 02.16-2BH

MATCHING

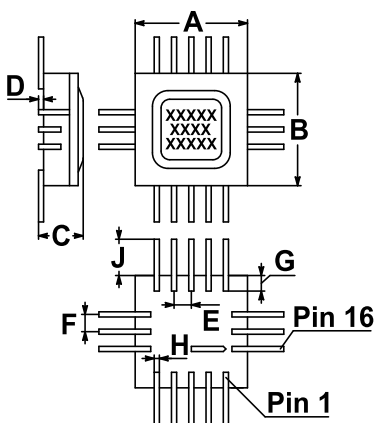

<http://aec-pro.com/cases.php>



DIMENSIONS (mm)	
A	6.5
B	6.5
C	2.9
D	0.2
E	1
F	1
G	0.9
H	0.3
J	3

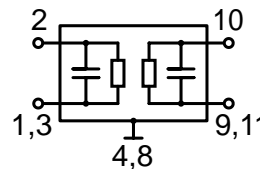

Input 50 Ohm		Output 50 Ohm	
L1, nH	-	L2, nH	-
C1, pF	-	C2, pF	-

Signal input: 2  
 Ground (input): 1,3  
 Signal output: 10  
 Ground (output): 9,11  
 Ground: other pin

\*Matching condition depends on PCB layout.

Recommendations:

- See the relevant ЦПАР for maximum permissible input signal power in the bandwidth.
- Input signal amplitude in the stop band is limited to 5 V.
- DC voltage at the input (output) of the filter should not exceed 10 V.
- It is recommended to include the coupling capacitor between the device and the generator (load).
- SAW filters are sensitive to static electricity, therefore corresponding precautions should be taken while working with them.
- Do not expose the device to frequency vibrations more than 5 kHz. Do not use ultrasonic cleaners.

Design and production SAW filters, resonators, delay lines, sensors.

**AEK** Ltd. AEC Mass production. Acceptance - QCID.  
[aec@aec-pro.com](mailto:aec@aec-pro.com) | tel./fax (812)252-93-70

**AEC** Ltd. AEC Design Design and production. Military acceptance.  
[admin@aec-design.com](mailto:admin@aec-design.com) | tel.(812)377-04-26 | fax.(812)364-60-69